



PROFILE SPOTS



Patt 23/S, 23F/S, 23W/S, 250/500 Watt

These compact spotlights, with four built-in but externally operated shutters, project a clear cut even beam of any profile determined by the shutters or a cut-out mask inserted in the gate runners. Four masks of fixed but different diameter apertures are provided for circular beams. Alternatively purpose-made masks can be used for pattern projection.

Different lens combinations are available so that the most efficient use can be made of the light collected at the gate by the front annular and rear ellipsoidal reflectors. The Fresnel lens model, Patt 23F/S, provides a diffused edge to the beam.

These spotlights are recommended for applications where quick but precise control of beam shape and spread is required as in stage and studio lighting. For the small scale stage they are ideal for the all-important lighting from the auditorium and also for side lighting close to a simple cyclorama.

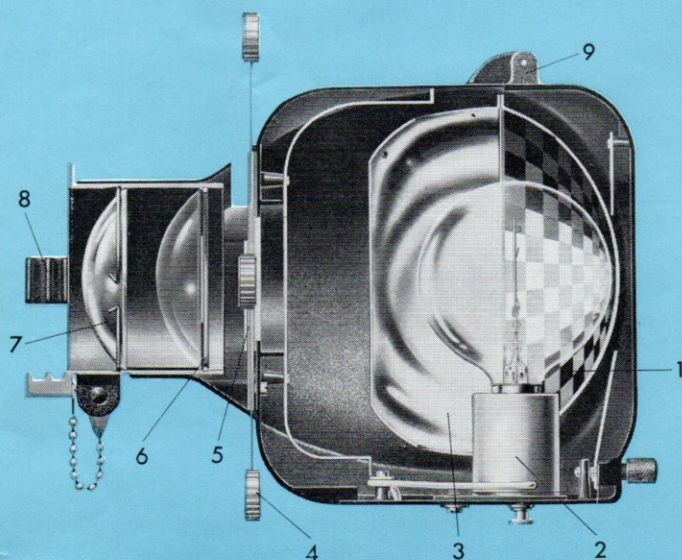

1. 7-in. diameter faceted ellipsoidal reflector
2. Medium pefocus lampholder
3. 7-in. diameter annular reflector
4. Four externally operated beam-shaping shutters
5. Gate runners for fixed aperture mask
6. Fixed aperture diaphragm to intercept stray light; also position for second $3\frac{1}{2} \times 5$ -in. lens for Patt 23W/S
7. $3\frac{1}{2} \times 5$ -in. lens for Patt 23/S, or $3\frac{1}{2} \times 4$ -in. Fresnel lens for Patt 23F/S, in sliding lens tube provided with safety chain
8. Double colour frame runners
9. Hinged rear door for interior access

← 12" (305mm) min.
14" (355mm) max. →

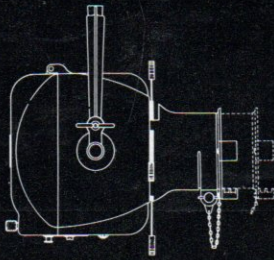

SCALE 1:10

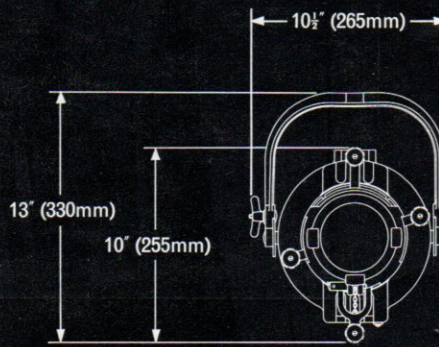

WEIGHT

Patt 23/S 6 1/2 lb. (3 kilos)

LAMPS & PERFORMANCE DATA

	THROW DISTANCE		BEAM SPREAD		ILLUMINATION							
	feet	metres	feet	metres	500W 120V 500T20/48 or Philips 559C		500W 240V Class T/1 or Philips 559C		250W 120V 250T20/47 or Philips 558C		250W 240V Class T/3 or Philips 558C	
					f.c.	lux	f.c.	lux	f.c.	lux	f.c.	lux
Pattern 23/S	25	9	8	3	47	360	30	230	20	155	21	160
BEAM ANGLE 20° <small>In which intensity varies 2:1</small>	30	10	10	3.5	32	290	21	185	14	125	15	130
	35		12		24		15		10		11	
Pattern 23F/S	20	7	10	3.5	49	395	38	305	19	155	19	155
BEAM ANGLE 30° <small>In which intensity varies 2:1</small>	25	9	13	4.5	31	240	24	185	12	95	12	95
Pattern 23W/S	15	5	10	3	52	470	47	425	28	250	33	300
BEAM ANGLE 36° <small>In which intensity varies 2:1</small>	20	7	13	4.5	29	240	27	215	16	130	19	155

SPECIFICATION

The spotlight shall be constructed of aluminium alloy pressure die-castings with baffled ventilation slots and shall contain a prefocus lampholder, a faceted ellipsoidal reflector, an annular reflector, four externally operated beam-shaping shutters, gate runners and an adjustable lens. The medium prefocus (P28) porcelain lampholder for a 250 or 500-watt projection lamp shall be fitted with 30-in. (0.75m) external length of heat-resisting cable (with earth/ground conductor) which shall be provided with a strain relief gland.

The 7-in. (180mm) diameter faceted ellipsoidal reflector and annular spherical reflector shall both be of polished anodised aluminium. The rear of the housing, together with the rear reflector, shall hinge upwards to provide interior access but shall normally be secured by a captive thumbscrew.

The four beam-shaping shutters shall be of planished steel and provided with external heat-resisting knobs. Gate runners shall be provided and four fixed, but different, circular aperture masks supplied.

The lens shall be recessed within a die-cast tube which shall be fitted with a fixed aperture diaphragm. The sliding lens tube shall be locked by a tommy-bar thumbscrew and shall be provided with a safety chain. Double die-cast

colour frame runners shall be provided and one 4×4-in. (100×100mm) metal colour frame supplied.

The lens fitted shall be as follows:

Patt 23/S - one 3 1/2×5-in. (90×125mm) plano conv.

Patt 23F/S - one 3 1/2×4-in. (90×100mm) Fresnel.

Patt 23W/S - two 3 1/2×5-in. (90×125mm) plano conv.

The spotlight shall be mounted in a reversible malleable die-cast fork with friction disc tilt clamp and 3/8-in. bolt and wing nut for suspension.

The exterior and fork shall be smooth finished with epoxy resin hard hammer grey and the interior, excepting reflectors and gate shutters, flat black.

VARIATIONS available at time of manufacture

Heat-resisting rear handle (add suffix -/H).

6-ft (1.8m) heat-resisting flexible cable.

Tilt and swivel scale indication.

ACCESSORIES

Ref. 374. Diffuser glass in frame for Patt 23/S, 23W/S.

Ref. 592. 1 1/2-in. diameter hollow TV spigot.